

7 - Instrument panel

Instrument panel system

The instrument panel consists of a digital LCD unit.

Displayed information are made available via a rocker button with two positions (1) and the flasher button (2) on the left-hand switchgear.

On the sides of the digital unit are 6 warning lights (three on either side) other than some auxiliary warning lights that indicate limiter kick-in threshold.

The instrument panel fits a sensor detecting light brightness of the environment where the bike is. According to this value, the instrument panel automatically turns on or off the backlighting. The instrument panel is also equipped with a built-in temperature sensor that outputs a signal controlling backlighting switch-off to avoid damages in case temperature is too high (70 °C).

A barometric pressure sensor is integrated inside the instrument panel: the engine control unit gets these data through the CAN (controller area network) communication serial line.



Warning lights

The following warning lights are present on the instrument panel.

- 3) Neutral light N (green): comes on when gearchange is in neutral.
- 4) Low fuel light (yellow): comes on when there are about 3 litres of fuel left in the tank.
- 5) Turn indicators light (green): the light relevant to the active turn indicator comes on and flashes.
- 6) Engine oil pressure light (red): turns on to indicate low oil pressure. It briefly comes on when the ignition is switched to ON and normally goes out a few seconds after engine starts. It may shortly come on when the engine is hot, however, it should go out as the engine revs up.
- 7) High beam light (blue): comes on to indicate that high beam is on.
- 8) "Engine Diagnosis" light (amber): comes on permanent when a problem connected to the engine and/or injection system occurs.
- 9) Limiter lights

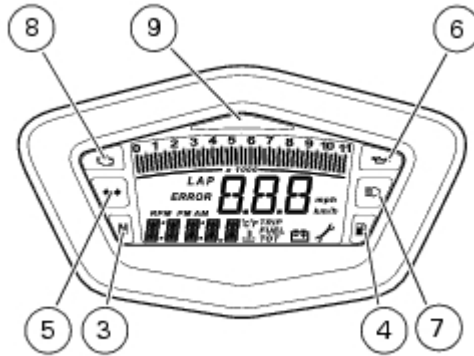

Display settings and functions

When the key is turned from OFF to ON, the Dashboard turns on all LCD digits for one second and all warning lights one by one.

It then switches to "normal" display mode showing the model indication in place of the odometer readout and the version (EU, UK, USA, CND, FRA, JAP) for 2 seconds.

Model is displayed once as scrolling text.

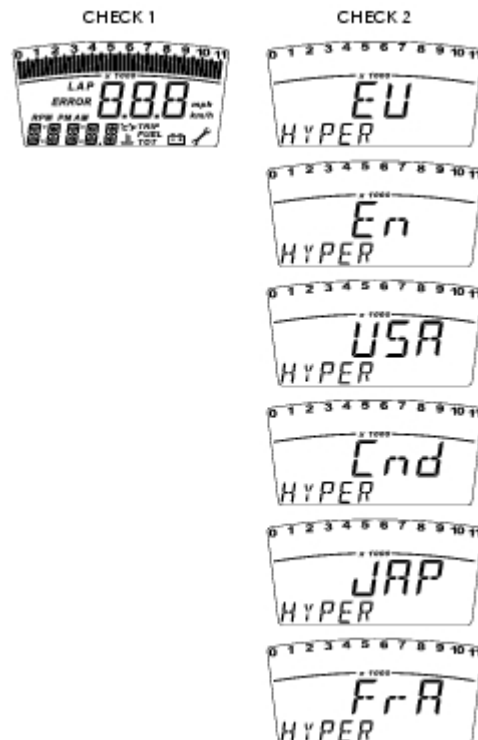

Upon Key-On, the Dashboard always displays the following information (and any functions activated previously are deactivated):

Odometer

Speed
Engine rpm

Pressing the button (1, fig. 8) to B "t", the Odometer readout will cycle through the following functions:

TRIP
TRIP FUEL (only if active)
Clock
T.OIL (only displayed when engine is ON)
until cycling back to the TOT function.

Pressing button (1, fig. 8) in position A "s" gives access to the MENU and the following functions are displayed one after another:

Error (only if active)
RPM
BATT
LAP (OFF or ON)
LAP MEM
Clock setup
code (only if active)

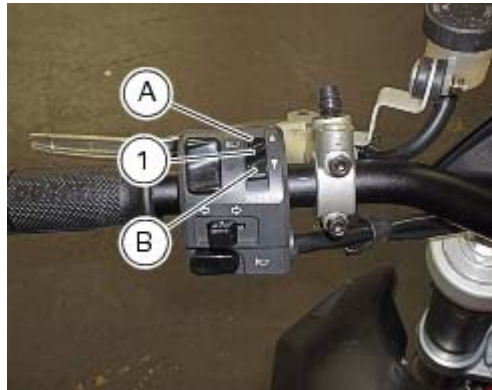

Caution

This menu is only active when the vehicle is stopped (speed is zero); if this MENU is open while the vehicle is running, the instrument panel will exit it automatically and go back to the start-up display screen; you may exit the menu at any time by holding button (1) depressed in position A "s" for 3 seconds.

Total distance covered indicator: "Odometer"

Upon Key-On, the system automatically enters this function.

The odometer reading is stored permanently and cannot be reset.

When the reading reaches 99999 Km (or 99999 mi), "99999" is displayed permanently.

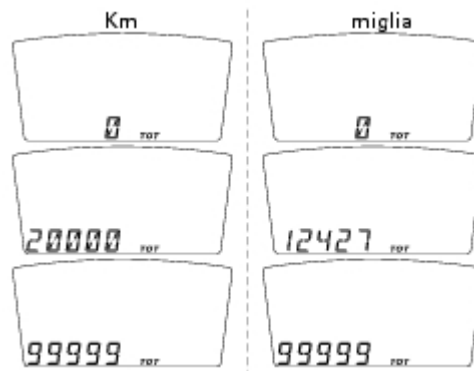

"Speed" indicator

This function shows vehicle speed.

Speed indication is obtained from actual speed information (in km/h) from the ECU increased by 8%.

Maximum speed displayed is 299 km/h (186 mph).

Over 299 Km/h (186 mph), the instrument panel will show a string of dashes " - - - " (not flashing).

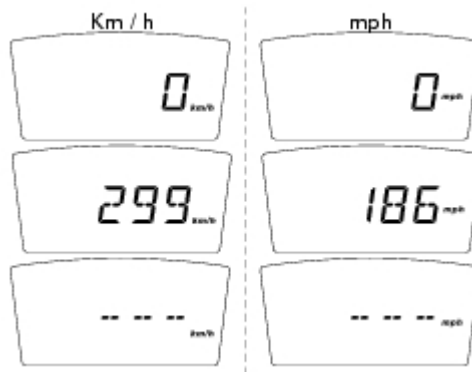

"TRIP A" meter

Holding button (1) pressed in position B "t" for 3 seconds when this function is displayed resets the trip meter. When the reading exceeds 999.9, distance travelled is reset and the meter automatically starts counting from 0 again.

If, at any time, system units of measurement are changed by means of the "Setting Special" function, distance covered indication within this function is reset and count restarts from zero, considering the new units of measurement.

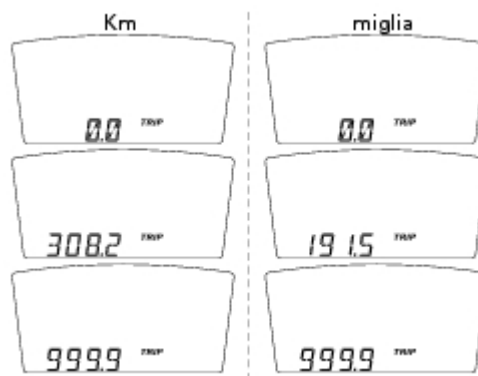

Distance travelled on fuel reserve: "TRIP FUEL"

When vehicle is running, the TRIP FUEL function is turned on automatically if the low fuel warning light (4) comes on, no matter which function was displayed. Trip fuel reading remains stored even after Key-Off until the vehicle is refuelled.

Count is interrupted automatically as soon as fuel is topped up to above minimum level.

When the reading exceeds 999.9, distance travelled is reset and the meter automatically starts counting from 0 again.

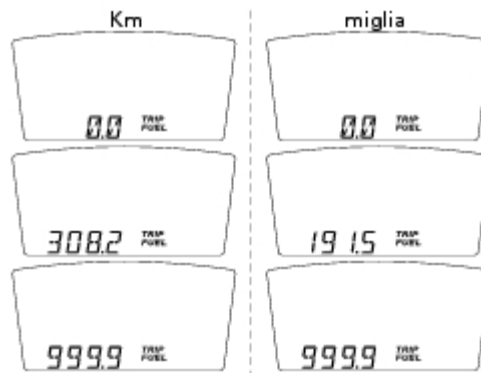

Engine coolant temperature indicator

It shows engine coolant temperature:



Caution

This indication is only active when the engine is running.

If reading is $-40\text{ }^{\circ}\text{C}$ ($^{\circ}\text{F} -104$) or less, the display shows a string of flashing dashes ("---") and the Engine Diagnostic light (8) comes on;

if reading is between $-39\text{ }^{\circ}\text{C}$ ($^{\circ}\text{F} -102$) and $+39\text{ }^{\circ}\text{C}$ ($^{\circ}\text{F} +102$), the word "LO" comes on steady on the display;

if reading is equal of higher than $+40\text{ }^{\circ}\text{C}$ ($^{\circ}\text{F} +104$) and $+170\text{ }^{\circ}\text{C}$ ($^{\circ}\text{F} +338$), the display shows temperature reading (on steady);

if reading is $+171\text{ }^{\circ}\text{C}$ ($^{\circ}\text{F} +340$) or above, the word "HI" is shown flashing on the display;

In the event of a sensor FAULT, a string of flashing dashes ("---") is shown and the Engine Diagnostic light (8) comes on.



Note

When temperature is $+171\text{ }^{\circ}\text{C}$ ($^{\circ}\text{F} +340$) or higher, the instrument panel will automatically switch from the set function to the flashing "HI" display.

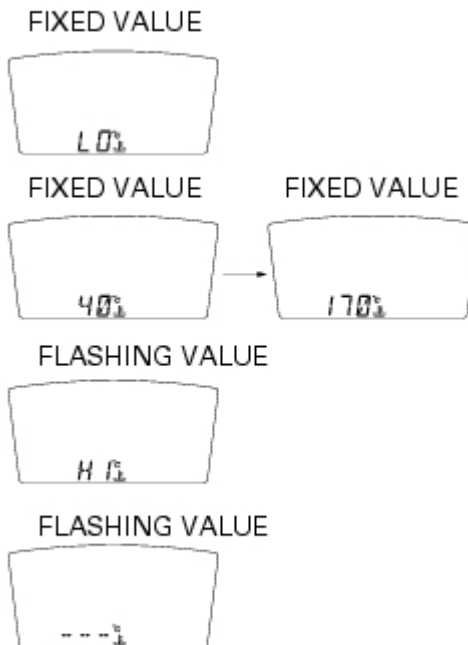

Maintenance indicator

It shows service intervals (service).

Indicator (🔧) comes on to indicate that the vehicle is due for service.

The display shows the service reminder at the following intervals:

when the odometer reaches 1000 Km;

every 12,000 Km.

The indication remains displayed until it is reset.

When the message appears, contact an authorised dealer or service centre.



Instrument panel diagnostics



Caution

The instrument panel correctly runs system diagnostics after 60 seconds from the last Key-Off.

Any faulty vehicle behaviour is displayed.

If more errors are present, they are displayed one by one every 3 seconds.





















Possible errors are listed in the table below.

















Warning

When an error is displayed, always contact an authorised Ducati workshop.

Warning light	Error message		Error
	COIL	10.1	Horizontal cylinder coil error
	COIL	10.2	Horizontal cylinder coil error
	COIL	11.1	Vertical cylinder coil error
	COIL	11.2	Vertical cylinder coil error
	INJE	12.1	Horizontal cylinder injector error
	INJE	12.2	Horizontal cylinder injector error

			
	INJE	13.1	Vertical cylinder injector error
	INJE	13.2	Vertical cylinder injector error
	PUMP	16.0	Fuel pump relay error
	STRT	19.1	Solenoid starter error
	STRT	19.2	Solenoid starter error
	STEP.	21.1	Stepper motor error
	STEP.	21.2	Stepper motor error
	STEP.	21.3	Stepper motor error
	LAMB.	22.1	Lambda sensor heater error
	LAMB.	22.2	Lambda sensor heater error
	EXVL	23.1	Exhaust butterfly valve motor error
	EXVL	23.2	Exhaust butterfly valve motor error
	EXVL	23.3	Exhaust butterfly valve motor error
	EXVL	23.4	Exhaust butterfly valve motor error
	EXVL	23.5	Exhaust butterfly valve motor error
	TPS	1.1	Throttle position sensor error
	TPS	1.2	Throttle position sensor error
	PRES	2.1	Pressure sensor error
	PRES	2.2	Pressure sensor error
	T.OIL	3.1	Engine oil temperature sensor error

	T.OIL	3.2	Engine oil temperature sensor error
	AIR	4.1	Air temperature sensor error
	AIR	4.2	Air temperature sensor error
	BATT	5.1	Battery voltage error
	BATT	5.2	Battery voltage error
	LAMB	6.1	Lambda sensor error
	TILT	6.2	Lambda sensor error 2
	ECU	30.0	Generic Engine Control Unit error
	PK.UP	34.0	Pick-up sensor error
	SPEE.	36.0	Speed sensor error
	IMMO	37.0	Immobilizer error
	IMMO	37.1	Immobilizer error
	IMMO	37.4	Immobilizer error
	IMMO	37.5	Immobilizer error
	CAN	38.0	CAN communication line error

Battery voltage indicator (BATT)

To view this function, access the menu and enter the "BATT" page.

The display shows battery voltage indication as follows:

if voltage is between 12.1 and 14.9 Volt, the reading is on steady;

if voltage is between 10.0 and 12.0 Volt or between 15.0 and 16.0 Volt, the reading will be flashing;

if voltage is 9.9 Volt or less, the word " LO " is shown flashing and the Vehicle Diagnostic light (8) comes on;

if voltage is 16.1 Volt or higher, the word " HI " is shown flashing and the Vehicle Diagnostic light (8) comes on;

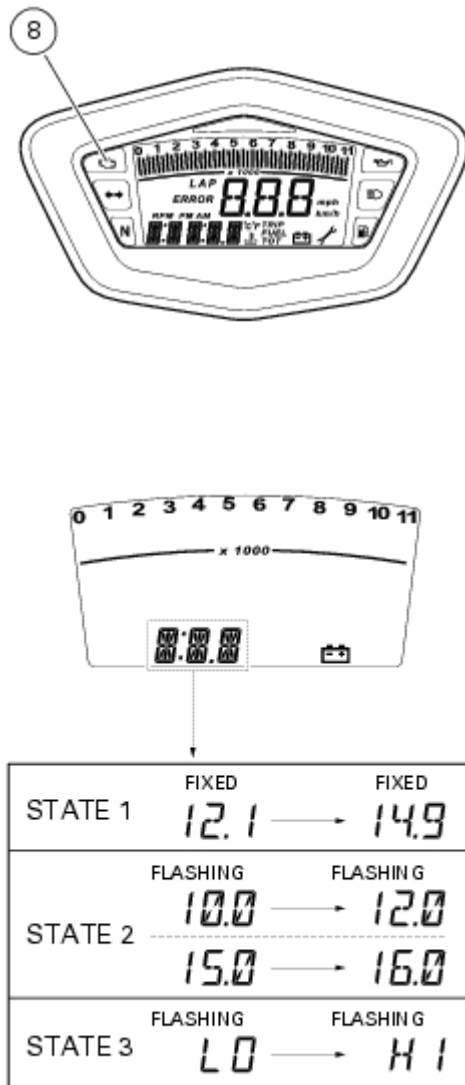

Engine idle speed adjustment (RPM)

To view this function, access the menu and enter the "RPM" page.

In addition to the rev counter scale at the top, the display shows engine rpm as a numeric value for improved accuracy when setting idle rpm.

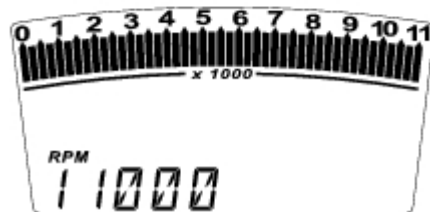
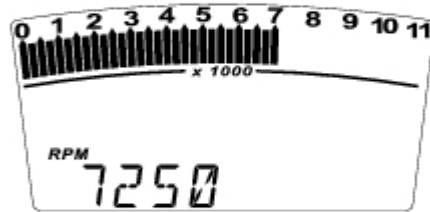
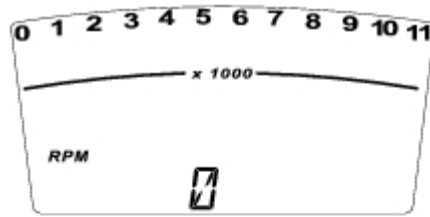

Lap timer activation and display (LAP function)

To enable this function, enter the menu and set the "LAP" function to "On" by holding button (1) pressed in position B "t" for 3 seconds.

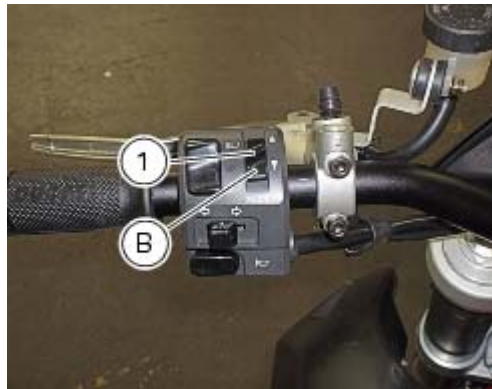

Once you have set the LAP function to On, exit the menu (press A for 3 seconds); the system will exit the menu automatically at any vehicle speed other than 0.

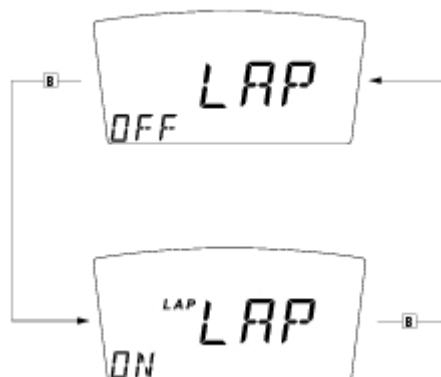

The lap timer is started and stopped using the high-beam flasher button FLASH (2) on the LH switch. Each time the FLASH button is pressed when the LAP function is active, the display will show lap time for 10 seconds and then revert to "normal" display mode.

Up to 30 lap times can be stored.

When the memory is full, each time the FLASH button is pressed the word "FULL" is shown flashing for 3 seconds instead of lap time until stored times are reset.



When the LAP function is set to Off in the menu, the current "lap" is not stored.

The LAP function is disabled automatically if the display is turned to Off (Key-Off) while it is active and the current "lap" is not stored even though the lap timer had been active before Key-Off.

If the lap timer is not stopped, upon reaching 99 minutes, 59 seconds and 99 hundredths, it will start counting from 0 (zero) and will keep running until the function is disabled.

If the LAP function is enabled without resetting the "memory" and there are less than 30 laps stored in the memory (for instance: 18 laps stored), the display will store new laps until the memory is full (in this instance, 12 more laps).

This function only lets you view lap times; lap times are stored in the Lap Memory function.

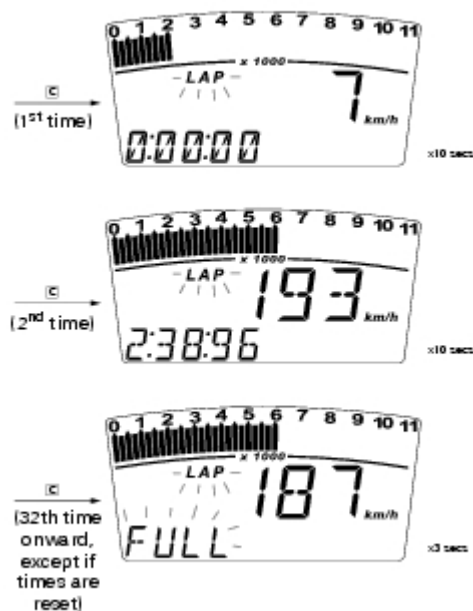

Stored data display (LAP Memory)

Displays data stored using the LAP function: lap number and lap time.

To view stored lap times, enter the menu and go to page "LAP MEM".

In this menu page, press button (1) in position B "t" to view the "1st lap"; the display will show lap number

and lap time.

Press button (1) in position B "t" repeatedly to scroll through the 30 laps stored until returning to the 1st lap. If button (1) is hold depressed in position B "t" for 3 seconds while viewing lap times, the display will instantly reset all stored lap times and the LAP function is disabled automatically, if active.

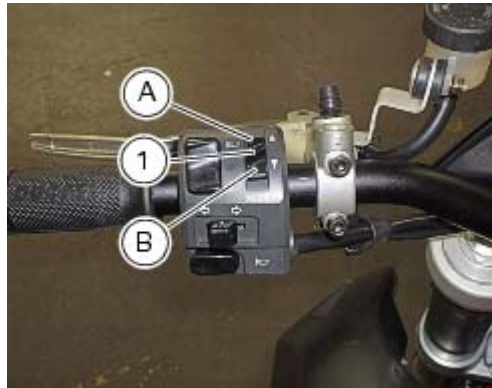

To exit the stored lap time display mode, press button (1) in position A "s".

If no lap is stored in the memory, the display will scroll through 30 laps with all lap times reading "00.00.00".

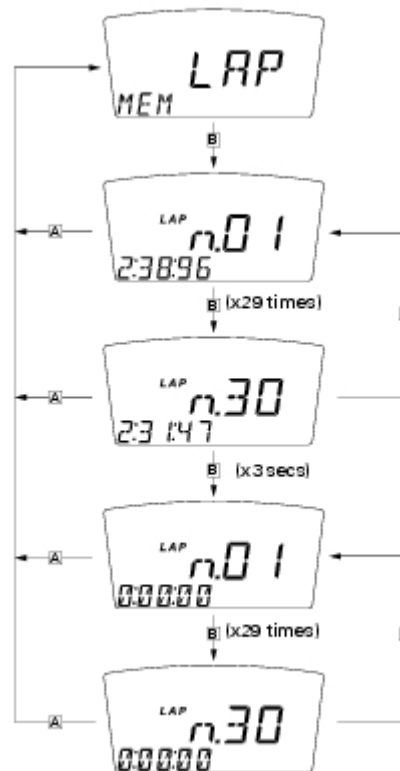

If, while running, the engine has reached one of the two thresholds before the limiter kicks in or the limiter trigger value, the relevant warning lights (9) are turned on while viewing the stored lap times.

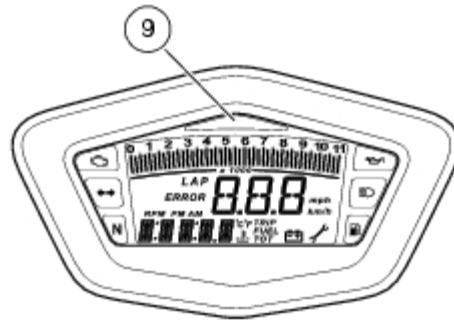

USB data logger (Activation / Deactivation)

This function turns on the USB data logger (Sect. P 10, [USB data logger](#)): ensure that data logger is connected to the vehicle wiring or it will not record any data.

To enable the data logger, enter the menu and set the "LAP" function to "On" by holding button (1) pressed in position B "t".

The START/STOP control for the data logger lap separator is the high-beam flasher button FLASH (2) on the LH switch.

If the key is turned to Off (Key-Off) while the LAP function is active and the (USB) data logger is operating, the function is disabled automatically.



Clock setting function

To set the clock, enter the menu page "TIME Set".

Holding button (1) pressed in position B "t" for 3 seconds in this menu page gives access to the setup mode. When you access this function, the word "AM" flashes; pressing button (1) in position B "t" switches to "PM" (flashing); pressing button (1) in position B "t" returns to the previous step (if clock time is 00:00, it will switch to 12:00 when you toggle from AM to PM); pressing button (1), in position A "s" switches to hour setup (flashing). At each press of the button in position B "t", hours will increase by 1 unit; if the button is held depressed in position B "t", hour setting will increase by 1 hour per second (hours do not flash when the button is held depressed).

Pressing button (1) in position A "s" gives access to the minute setting mode; minutes start to flash. At each press of the button in B "t", minutes increase by 1 unit; if the button is held depressed in position B "t", minutes increase by 1 minute per second. If the button is held depressed in position B "t" for over 5 seconds, minutes will increase by 1 minute every 100ms (while the button is held depressed in position B "t", seconds will not flash). Pressing the button in position A "s", exits setup mode and the set time is displayed.



Note

Hour setting is reset when power fails (Battery-Off). When power supply is restored (Battery-On) 0:00 is displayed. It is then necessary to set correct time.

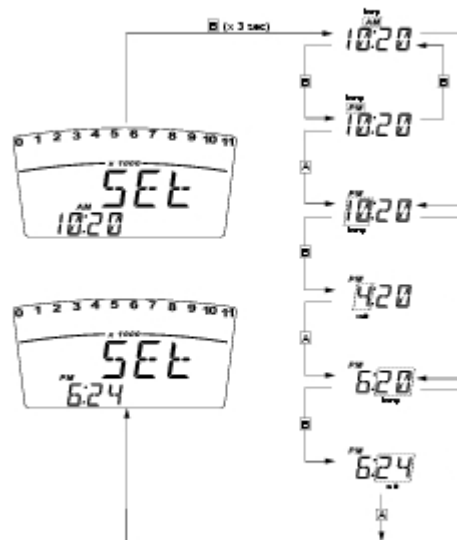
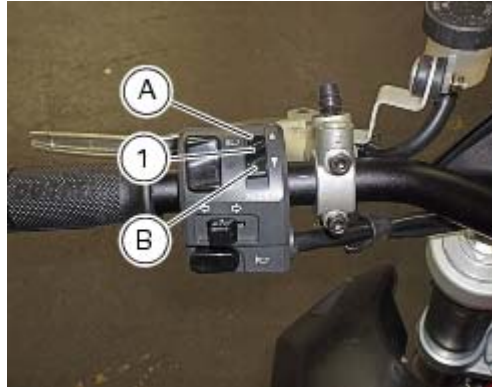

Immobilizer override procedure

In case of an "Immobilizer BLOCK", it is possible to perform an "Immobilizer Override" procedure through the instrument panel, after entering the corresponding function, as described below. Enter the menu and go to page "cod".



Note

This menu is only active when at least one Immobilizer error is present.

This page menu shows a default "00000" code; press button (1) in position B "t" for 3 seconds to access the electronic code entry procedure.

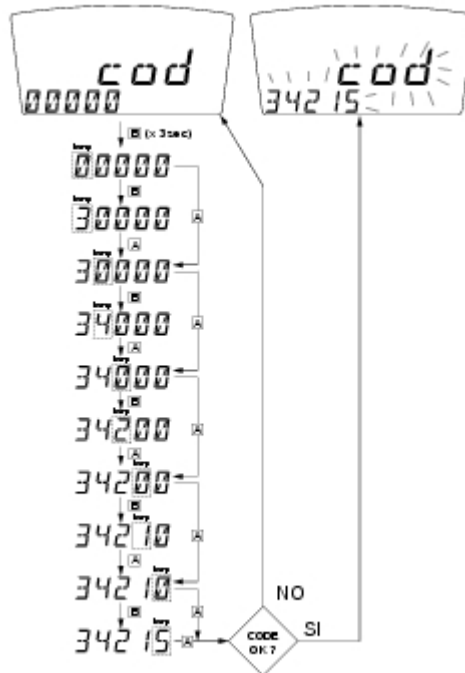

Entering the code:

when you access this function, the first digit on the left will flash.

Push-button (1):

each time you press the button in position B "t", the digit will increase by one unit per second;

if you press the button in position A "s", you will move to the second digit, which will start to flash. Each time you press the button in position B "t", the digit will increase by one unit per second;

If you press the button in position A "s", you will move to the third digit, which will start to flash. Each time you press the button in position B "t", the digit will increase by one unit per second;

if you press the button in position A "s", you will move to the fourth digit, which will start to flash. Each time you press the button in position B "t", the digit will increase by one unit per second;

if you press the button in position A "s", you will move to the fifth digit, which will start to flash. Each time you press the button in position B "t", the digit will increase by one unit per second;

press the button in position A "s" to confirm the code.

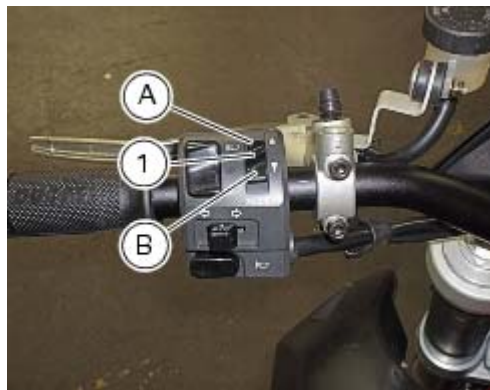

If code is incorrect, the display will again show the default code "00000". A wrong code can be entered countless times.

If the code has been entered correctly, the word "cod" and the code you just entered will flash for 4 seconds; the Diagnostic light (8) goes out; the instrument automatically exits the menu and the engine start-up inhibition is temporarily overridden.



If the error is still present at the next Key-On, the instrument panel error and the inhibited status will persist.

Headlight auto-off

This function allows you to reduce current consumption from the battery, by automatically managing headlight switching-off. The device is enabled in three instances:

- 1) When the key is turned from OFF to ON and the engine is not started within 60 seconds, the headlight is turned off and will be turned back on next time you start the engine.
- 2) When the vehicle has been running with the headlights on and the engine is stopped using the RUN-STOP button on the RH switch. In this case, 60 seconds after stopping the engine, the headlight is turned off and will be turned back on next time you start the engine.
- 3) While starting the engine.

Service Menu

The instrument panel features a service menu that should be used only by the dealer, in case of real need. To enter this service menu, hold button (1) pressed in position A "s" and at the same time turn the key from Off to On.



Note

Within this menu, any other function as well as engine starting is inhibited.

Pressing button (1) in position A "s" or B "t" the available functions are displayed one after the other. After enabling functions and/or changing settings, turn the key from ON to OFF to store any changes. Upon the following Key-On, the new settings will apply.

This menu features three functions:

- Immobilizer Reprogramming (PRO 0000);
- Unit of measurement setting for displayed values (SET UNIT);
- "Manual" movement of the exhaust butterfly valve (SET EXVL);
- Rear indicators setting (SET INDIC).

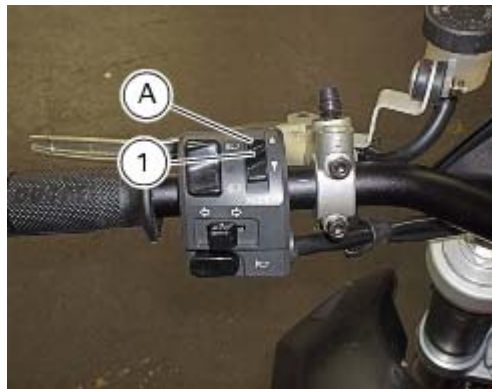

Immobilizer Reprogramming

This function allows for the reprogramming of the Immobilizer System in case one or both keys are missing/lost or damaged.

To view this function, access the "Service Menu" and enter the "Pro" page.

This function shows a default "00000" code; press button (1) in position B "t" for 3 seconds to access the electronic code entry procedure (code can be found on CODE CARD).

Entering the code:

the first digit on the left starts flashing;

each time you press the button in position B "t", the digit will increase by one unit per second;

if you press the button in position A "s", you will move to the second digit, which will start to flash. Each time you press the button in position B "t", the digit will increase by one unit per second;

If you press the button in position A "s", you will move to the third digit, which will start to flash. Each time you press the button in position B "t", the digit will increase by one unit per second;

if you press the button in position A "s", you will move to the fourth digit, which will start to flash. Each time you press the button in position B "t", the digit will increase by one unit per second;

if you press the button in position A "s", you will move to the fifth digit, which will start to flash. Each time you press the button in position B "t", the digit will increase by one unit per second;

press the button in position A "s" to confirm the code.

If code is incorrect, the display will again show the default code "00000". A wrong code can be entered countless times.

If the code is correct, "Pro." wording and the entered code will flash; now take the key to Off.

From this moment on, the Immobilizer System is waiting to be Reprogrammed with the new key (or keys);

upon the following Key-On it will be necessary to carry out a key programming procedure using the procedure described under "Programming the immobilizer".



Note

During this stage the Immobilizer System disables engine starting until keys are reprogrammed.

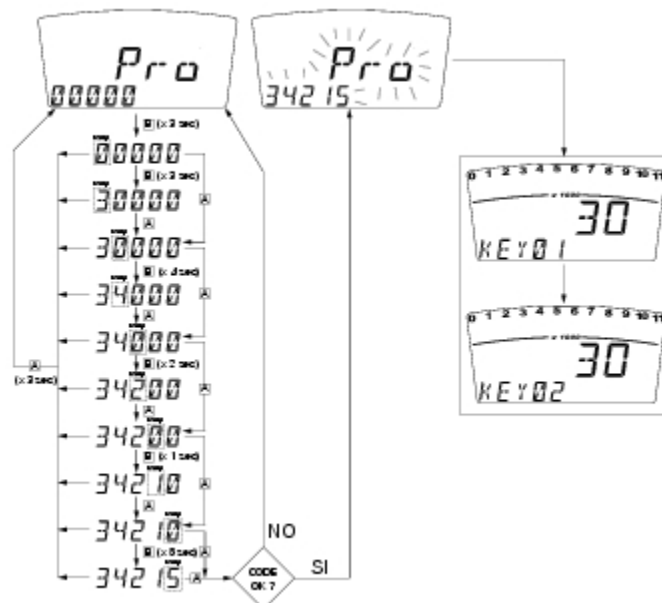
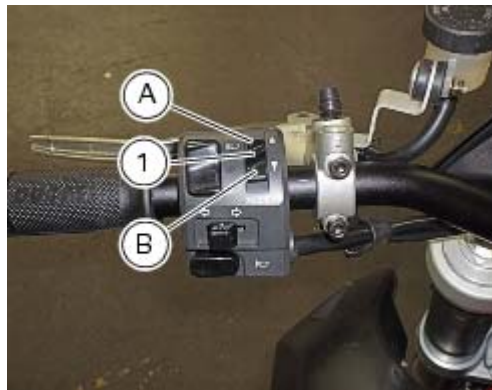

Code Card is missing

Since the Electronic Code indicated on the CODE CARD is no longer available, it will not be possible to: reprogram the Immobilizer System in case one or both keys are lost/missing; temporarily "override" the system in case of a fault to the Immobilizer System. To restore System normal operation it will be necessary to change the KEY SET (2 black keys + new CODE CARD) and the Instrument panel and then perform a new Immobilizer Programming.

One key is missing

After buying a new key, it is necessary to carry out a Reprogramming procedure (entering the code indicated on the CODE CARD) with the new key and the existing key (not lost/missing).

Both keys are missing

After buying two new keys, it is necessary to carry out a Reprogramming procedure (entering the code indicated on the CODE CARD) with the new keys.

Replacing the locks set (new locks + new Code Card + new keys)

After installing the new locks set, use the two new keys to Reprogram the system (entering the electronic code indicated on the **old** CODE CARD). Keep the new CODE CARD in a safe place since it could become "active" if the Instrument panel is replaced in the future and then needs a new programming procedure.

Instrument panel replacement

After buying the new instrument panel, perform a normal "Programming" of the Immobilizer System.

Instrument panel replacement after one or both keys were changed

For this special case, for the whole Immobilizer System to work correctly, before Programming the Immobilizer it is necessary to change the KEY SET as well (2 black keys + new CODE CARD). If the new instrument panel is programmed with the existing keys, previously replaced, the System programming will be successful and will allow engine starting but the Electronic code on the CODE CARD will no longer allow you to: reprogram the Immobilizer System in case one or both keys are lost/missing; temporarily "override" the system in case of a fault to the Immobilizer System.

"Setting Special" function (vehicle model and units of measurement)

This function allows you to change the units of measurement for the values displayed on the instrument panel. The control unit automatically informs the instrument panel about the correct vehicle model and unit of measurement to be displayed: to force these parameters, enter the "Service menu" and use "SET UNIT" function. Then press button (1) in position B "t" and hold for 3 seconds. Every time the button (1) is pressed in position B "t", the Dashboard cyclically activates the following pages (flashing):

	Unit of measurement		
COUNTRY STANDARD	Speed	H ₂ O temperature	Odometer
EU	Km/h	°C	Km
UK	mph	°C	miles
USA	mph	°F	miles
CND	Km/h	°C	Km
FRA	Km/h	°C	Km
JAP	Km/h	°C	Km
ECU Id.	The instrument panel sets the unit of measurement according to the information received by the ECU		

Press button (1) in position B "t" and hold for 3 seconds to store displayed configuration; "MEM" is displayed.

Upon the following Key-On, the new settings will apply.

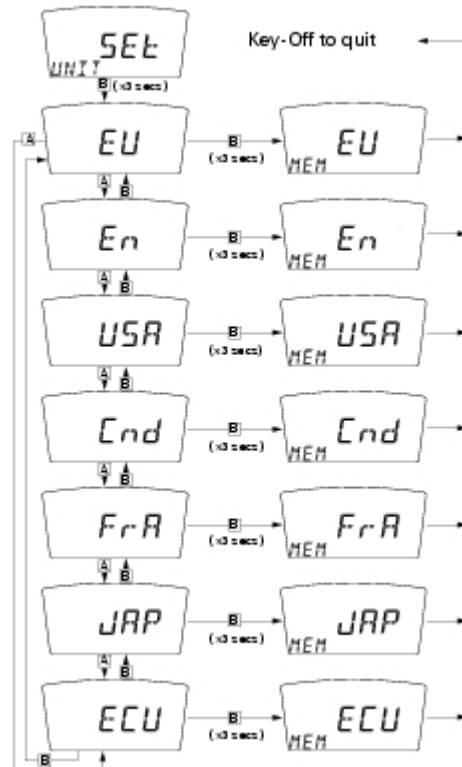
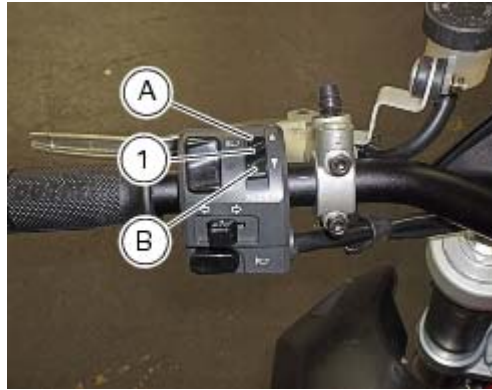

Exhaust Butterfly Valve Motor Movement for wires installation

This function allows you to move the exhaust butterfly valve motor to help you when refitting the wires. If you turn the key to On by accident when changing cables, i.e. with the valve motor not connected, the motor turns for a few seconds and stops in a random position. This prevents you from refitting the wires. It is necessary to use this function to take motor back to such a position so that it is possible to refit the wires.

To view this function, access the "SERVICE MENU" and enter the "Set EXVL" page.

Now, press button (1) in position B "t" and hold for 3 seconds to enter the "MOVE" mode allowing you to move the motor.

Hold button (1) in position A "s" to turn valve motor clockwise; hold button (1) in position B "t" to turn valve motor counter clockwise.

To ensure that wires can be refitted, turn motor until " 1.7 v " is displayed.

Take the key to Off to quit this function.



Note

If battery voltage is < 11 Volt, the motor will not turn when pressing button (1). When this function is active, no diagnosis is made and engine starting is disabled.

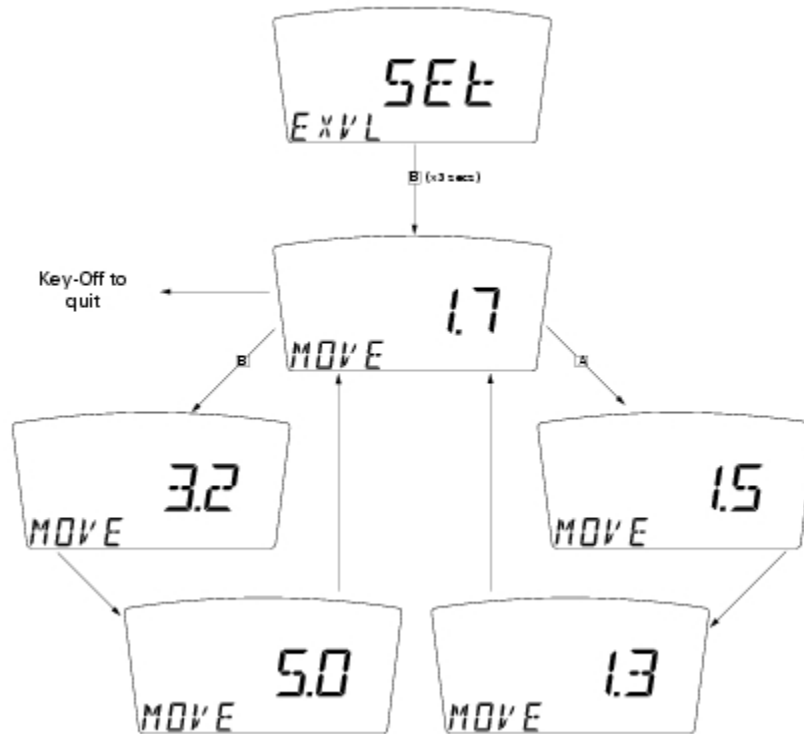

Programming the immobilizer

This instrument panel function allows for Immobilizer System programming.



Note

It is possible to store only 2 keys.

Insert KEY 1 (one of the two black keys) and turn it from Off to On;
 turn key to Off within 3 seconds;
 within 15 seconds, insert KEY 2 (the other black key) and turn it from Off to On;
 turn key to Off within 3 seconds;
 within 15 seconds, insert again KEY X (either Key 1 or Key 2, it does not matter) and turn it from Off to On.

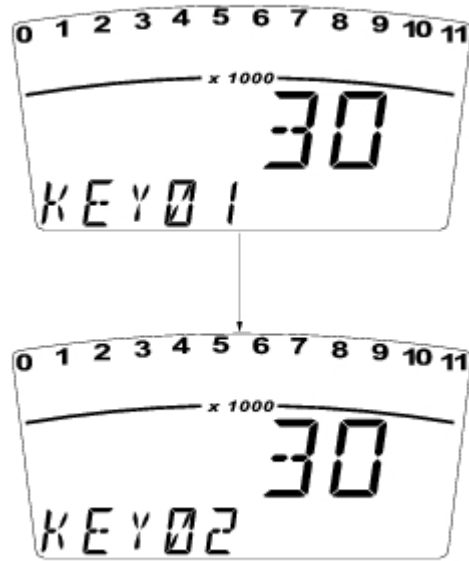

If the procedure is successful, the Dashboard will display "PROG" fixed for 3 seconds and then go back to normal display.

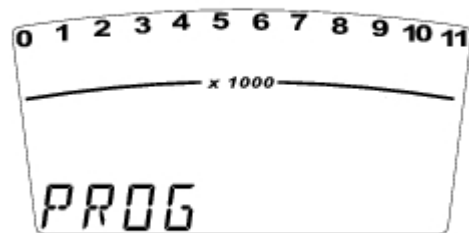

Programming aborted:

if the 3-second countdown after Key-On, the 15-second countdown after Key-Off reach zero or if programming procedure is incorrect, the Dashboard aborts the programming and will display "OFF" for 3 seconds and then go back to normal display.

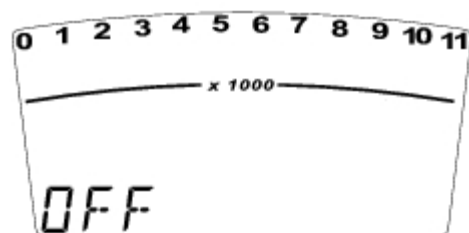

Caution

During the programming procedure, the Dashboard not only stores the key codes, but detects two "electronic" codes after KEY 1 (first black key inserted) and KEY 2 (second black key inserted) are inserted.

In case the Immobilizer is reprogrammed, the key codes are deleted and replaced by the new codes of the new keys; while the two "electronic" codes are forever stored with no chance to delete or overwrite them. The electronic code indicated on the CODE CARD corresponds to one of the two electronic codes and will be used for the procedures of Immobilizer Recovery and Immobilizer Reprogramming.

Service MENU - Rear Turn Indicators Setup

This Function allows you to set the correct piloting of the rear turn indicators.

The vehicle comes as standard with bulb rear turn indicators (10W); if the owner wishes to change them and fit Led Ducati Performance indicators, after installation it is also necessary to set them within this page of the Service MENU.

To view this function, access the "SERVICE MENU" and enter the "Set INDIC" page.

Then press button B for 3 sec. to enter the "SET" mode.

The display reads "LAMP" (bulb type); press button A (s) to switch to "LED" (Led type).

Once the correct type of turn indicator is set, press button B and hold for 3 sec. until "MEM" (memorised) is displayed.

Take the key to "OFF" to save and quit this function. Upon the following Key-On, the Dashboard goes back to normal operation.

